

Driveway & Miscellaneous Permits

SECTION 1

OF THE
REQUIREMENTS, REGULATIONS AND
SPECIFICATIONS
FOR
CONSTRUCTION WITHIN THE RIGHT-OF-WAY
OF PUBLIC ROADS
UNDER THE JURISDICTION OF THE

EMMET COUNTY ROAD COMMISSION

2265 E. HATHAWAY ROAD
HARBOR SPRINGS, MI 49740

(231) 347-8142

FAX (231) 347-5787

EMAIL ecrcpermit@emmetcrc.com

ADOPTED OCTOBER 7, 1994

LAST AMENDMENT DATE:

December 7, 2012

SECTION 1

Driveways and Miscellaneous Permits

TABLE OF CONTENTS

Part	Title	Page
1.1	Introduction	1-1
1.2	General Conditions	1-1
	Definitions	1-1
	Applicability	1-1
	Permit Necessity	1-2
	Commercial Driveways	1-3
	Activities not permitted in the Right of Way	1-4
	Processing of Permits	1-5
	Permit Period and Seasonal Limitations	1-5
	Protection of Existing Utilities	1-6
	Indemnity and Insurance	1-6
	Conditions and Limitations in Permits	1-7
	Fees, Costs and Sureties	1-8
	Enforcement	1-9
	Commercial Driveway Construction	1-10
1.3	Specifications and Design Standards	1-11
	Driveway Location	1-11
	Clear Vision and Buffer Areas	1-12
	Drainage	1-13
	Culverts	1-13
	Material and Density Requirements	1-14
	Surfacing	1-14
	Driveway Profile	1-15
	Restoration	1-15
	Plan Requirements	1-15
	Design Features	1-16
	Sign Requirements	1-17
	Permit Fee Schedule	1-18
	Figure 1-1: Driveways Other Than Commercial	1-19
	Figure 1-2: Commercial Driveways	1-20
	Figure 1-3: Driveway Profile Other Than Commercial	1-21
	Figure 1-4: Driveway Profile Commercial	1-22
	Figure 1-5: Driveway Cross Section	1-23
	Figure 1-6: Sign Location	1-24
	Endorsement #4	1-25

1.1 Introduction

A. The purpose of these regulations and specifications is:

1. To establish a uniform plan for the use of road right of way by adjacent property owners and public utility companies.
2. To ensure the safety of the public.
3. To ensure proper drainage of the public roads.
4. To prevent damage of public roads at the point of access.
5. To ensure that all proposed work in the right of way is approved by the commission and is performed by individuals who meet the insurance requirements of the Emmet County Road Commission.

1.2 General Conditions

A. Definitions

1. Applicant- Owner of the property served by the driveway.
2. Access or Haul Road- A driveway that is needed for any one of a variety of activities, such as: timber harvest, construction access, top soil stripping, borrows areas, mobile batch plants, ect. The use is light to heavy commercial in nature with either temporary or occasional use.
3. Circle Driveway- A private driveway that enters and leaves the property at two points within the same frontage.
4. Commercial Driveway- A driveway serving a commercial establishment, industry, governmental or educational institution, hospital, church, apartment building, 5 (five) or more lots, parcels, or single family homes.
5. Contractor- Any Company or person doing permit related work on behalf of the applicant, in the right of way.
6. Commission- The Emmet County Road Commission (ECRC).
7. Field Entrance- A driveway serving a farmyard, cultivated or uncultivated field, or undeveloped land not used for industrial, commercial or residential purposes. Nature of use is light or occasional.
8. Frontage- A private property line that abuts a road right of way.
9. Multifamily Residential Driveway – A driveway serving 2 (two) to 4 (four) lots, parcels, or single family homes.
10. Permittee- Also referred to as “permit Holder” is the property owner and/or Contractor (including sub-contractors).
11. Residential Driveway- A driveway serving 1 (one) single family home.
12. Right of Way Line- A boundary between private property and public land under legal control of the agency having control over the roadway.
13. Utility Structure Driveway – A driveway serving a utility structure such as a pump house or substation that operates automatically and requires only occasional access.

B. Applicability

1. The requirements listed in this section constitute the “supplemental specifications” referred to in item 15 of the permit terms listed on the reverse side of the APPLICATION AND PERMIT form.
2. **These rules apply to all right of way under the jurisdiction of the Commission.** These rules and specification do not apply outside the road right of way. Nothing in these rules shall be construed to prevent the application of the provisions of any other statute of this state or any local ordinance which is more restrictive than these rules, nor to

preclude any city of village from requiring city of village permits with respect to any street or roadway within its corporate limits and under its jurisdiction. No permit will be issued pursuant to these rules unless there is compliance with other provisions of law and ordinances.

3. **State Highways**

Driveways that access state highways require permits from the Michigan Department of Transportation (MDOT). MDOT permit applications are available at the Road Commission. The Emmet County Road Commission does not have jurisdiction over MDOT highways in Emmet County. All permit applications for MDOT highways must be sent directly to the MDOT at the following address:

MDOT Gaylord TSC	Voice: (989) 731-5090
1088 M-32 East	Fax: (989) 732-3637
Gaylord, MI 49735	

C. Permit Necessity

1. **All work in the road right of way.**

A person, organization, or governmental unit may not undertake any work within the road right of way, unless a permit had been obtained from the Commission. The following are examples of activities that require a permit:

- a.) Construct, reconstruct, relocate or surface a driveway or related construction.
- b.) A proposed driveway may not be used for access prior to obtaining a driveway permit and placing the required gravel base or surface.
- c.) Install public or private utilities.
- d.) Cutting or removing trees.
- e.) Landscaping, grading, ditching and ditch cleanout.

2. **Change in use:**

Changes in use of a driveway or property abutting a road may require changes in the number, design or location of driveways. The property owner or owner's representative must obtain a permit from the Commission, for the type of driveway for the new use, and will make all necessary improvements required to satisfy the specifications and standards of the type of driveway required for the new use. The following are examples of change in use, including, but not limited to:

- a.) Single Family Residential to Multifamily Residential
- b.) Residential to Commercial
- c.) Residential to Access or Haul Road
- d.) Field Entrance to Commercial, Residential, or Access or Haul Road
- e.) New home construction including modular and mobile homes. (The Building Department will not issue a building permit without a driveway permit.)

3. **Existing Driveways**

Commission personnel will do an onsite inspection to determine if the existing driveway satisfies the permit requirements for the intended use.

- a.) No improvements needed or planned
 - If the existing driveway satisfies the permit requirements for the intended use and the applicant does not intend to do any work in the road right of way, a permit can be issued for "NO IMPROVEMENTS REQUIRED." Because no work will be done or is authorized in the road right of way under this permit, there is no need for contractor information and signature. A new permit must be obtained when and if work is to be done in the right of way.
- b.) Improvements required by the Commission or planned by the applicant
 - If an existing driveway does not satisfy the permit requirements for the intended use, the applicant will be required to make all necessary

improvements as a condition of the permit. Contractor information and signature are required for issuance.

- If the applicant plans on making improvements to the existing drive or working in the right of way, the work must be authorized by the permit. All improvements to driveways shall be per the "ECRC standards and specifications." An existing driveway shall not be resurfaced or repaved without conforming to all the specifications such as culvert requirements, driveway dimensions, driveway profile, drainage, ect. Contractor information and signature are required for issuance.

4. Seasonal Roads

A Permit is required for driveways on seasonal roads and is subject to the following maintenance provisions:

- a.) If a seasonal road is used as an access road for commercial transport trucks, the road shall be maintained by the permit holder or user in a condition equal to or better than the road prior to use by said vehicles. The reason for this maintenance requirement is that seasonal roads are unimproved, in so far as they lack adequate base to support commercial truck traffic, and can become impassable to the public.

5. Mailboxes

Standard mailboxes are allowed in the road right of way without individual written permits. It is the mailbox owner's responsibility to ensure that their mailbox and post are installed according to US Postal Service requirements and as specified herein. Mailbox posts must be at least 8 feet off the 11 feet wide driving lane or placed with the front of the box 1 foot behind the outside edge of the maintained (plowed) shoulder. Post size and material is critical to roadway safety and may not exceed 4"x4" for wood or 3 lb/Foot for steel. No masonry, concrete or stone structures are permitted in the right of way. Multiple mailboxes shall not be placed on planks or structures. Each mailbox shall have its own post, with the exception that a plastic newspaper box may be attached to the same post as the mailbox. Oversized or decorative boxes and posts are placed at the owner's risk and are maintained and/or replaced at the owner's sole expense. The Commission will reimburse the owner of a box and/or post that has been *physically struck* by Commission equipment (not thrown snow). The amount of reimbursement will be the established amount set by the Commission's current Mailbox Replacement Policy, regardless of the actual cost of the box or post that was struck.

D. Commercial Driveways

Each Commercial Driveway Application will be reviewed on a case-by-case basis. The Road Commission has the right to require any or all of the following, to be satisfied prior to or to be in compliant with the issuance of the commercial permit. (Pursuant to Section 247.327, Section 4, of the Michigan Compiled Laws.)

1. Site Plan of the development.
2. Drainage Plans for the development showing no adverse impact of on-site drainage entering the road right of way. The developer may be required to provide drainage improvements within the right of way (by permit) to accommodate the drainage.
3. For Commercial Driveways where there are 25 or more homes or 50 or more parking spaces, a Traffic Impact Study showing impacts on surrounding road from the proposed development may be required along with any or all of the following:
 - a.) Should the Traffic Impact Study show a need for improvement to local or primary roads to accommodate the additional traffic, the developer would be required to develop a set of Engineered Plans for the county road improvements. The plans must be approved by Road Commission staff.

- b.) A Road Improvement Agreement between the developer and the Road Commission ensuring the developer would be responsible to improve any local and/or primary roads necessary to accommodate the additional traffic. (See Section J for fees to accommodate the county road improvements).
- c.) If improvements are necessary, the developer must contract with a reputable road-building contractor. The developer must have the work performed on the county road, inspected throughout construction and have the work certified by a Professional Engineer licensed in the State of Michigan that the road was built to Road Commission standards.
- d.) The developer shall provide all necessary daily inspection reports, base, subbase and asphalt density tests necessary to assure the Road Commission that the county road(s) has been built per Road Commission requirements.
- e.) Additional right of way necessary to accommodate the county road improvements will be the responsibility of the developer.
- f.) Any necessary utility relocation would be the responsibility of the developer.
- g.) Any other reasonable request to accommodate the additional traffic from the development, per Michigan Law.

E. Activities NOT permitted in the Right of Way

1. Accessing a public road with vehicles at any location other than a permitted and properly constructed driveway.
2. Filling roadside ditches with dirt, rocks, leaves, debris, ect.
3. Planting of trees, shrubs, seedlings or bushes of any kind.
4. Construction of a retaining wall or culvert headwall along the side of the road.
5. Placement of any type of fence.
6. Placement of rocks, boulders or earth berm.
7. Placement of political, real estate, advertisement or other unauthorized signs. Contact the township for setback from right of way and other requirements for signs.
8. Plowing snow into or across a public road. This can create a hazard to motorists and Commission plow drivers.
9. Placement of stakes, posts, fences, markers, rocks, signs or any other item in the road right of way for the purpose of restricting the use of the right of way by the public or the Commission. The Commission has sole and exclusive authority and jurisdiction over the use of the right of way and is the only body authorized to place such items. The Commission plows snow wider than the paved or traveled portion of a road, out of necessity and for public safety. Any attempt to restrict or interfere with the Commission's use, maintenance, construction or reconstruction of any portion of the right of way is prohibited. Encroachments that interfere with Commission activities or pose an immediate threat to public safety will be removed and disposed of (not salvaged) by the Commission, without notice to the owner, and at the owner's expense. Michigan law authorizes the Commission to initiate both criminal and civil action to remedy the situation.
10. Any other encroachment considered potentially hazardous by the Commission.
11. Any activity that causes damage to the right of way or road, such as driving off or onto the road where there is no driveway.
12. Underground Lawn Watering Sprinkler Systems are not allowed in the road right of way.
13. The road right of way shall not be used as a construction staging area.
 - a.) No loading or unloading of equipment or materials is permitted in the right of way except as needed to construct a driveway approach, and shall be done under traffic control.
 - b.) Stockpiling of materials or parking equipment in the right of way is not permitted.

- c.) Steel tracked vehicles shall not be unloaded, loaded or operated in the traveled portion of the road, including shoulders, without the proper protection of the road surface. Protection can be plywood, planks, tires, ect.. The permit holder is responsible for any damage to the road and road right of way.
- 14. Decking of logs, or other logging related items, is not permitted in the road right of way.
- 15. Loading or unloading of logs in the road right of way.

F. Processing of Permits

- 1. Processing Time
 - a.) Permits will usually be processed and issued in 5 (five) or less business days from the date received, provided that all required information, signatures, fees, sureties, ect. are received at the time of application.
 - b.) Incomplete applications will be delayed or not processed until all required information is received.
 - c.) Additional processing time may be needed for complicated applications, heavy application volume, reduced staffing levels, or Road Commission priorities.

G. Permit Period and Seasonal Limitations

- 1. Permit Period
 - a.) A permit is valid for a maximum of one year from the date of issuance. The permit period applies to work activities in the right of way required by the permit. Use of a permitted driveway is not limited to the permit period.
 - b.) Work authorized by the permit shall be completed to the satisfaction of the Commission on or before the completion date specified on the permit or one year after the issuance date, whichever comes first. A request for extension of time for completion of this work shall include reasons for the request, anticipated completion date, proof of insurance for that period. Approval for extension of time shall be based on circumstances and absence of neglect by the permit holder.
 - c.) If work authorized by the permit is not completed during the authorized extension, or an extension is denied by the Commission one of the following shall apply:
 - The applicant will be allowed to renew the permit (see item d below)
 - The Commission will undertake whatever enforcement action it determines to be appropriate in the interest of the Commission or the public.
 - d.) Permit renewal, if allowed, is the issuance of a new permit including the following:
 - New permit number.
 - Statement that this is a renewal of permit number (original permit number.)
 - Applicant information and signature.
 - Contractor information and signature.
 - Application fee will be charged at current rate.
 - Insurance and surety requirements maintained.
 - If a Surety and/or cash deposit were not required in the original permit, it may be required in the renewal of a permit, at the discretion of the Commission.
- 2. Seasonal Limitations
 - a.) No work shall be performed in the road right of way during the period of November 14 thru April 16 without specific permission from the Road

Commission. Each request will be evaluated based on weather, public safety concerns, impact on winter maintenance activities, ect..

- b.) The traveled portion of the road including shoulders and driveway approaches shall be completely restored by November 1, in preparation for winter maintenance (snow plowing). The Road Commission will take corrective action without notice and at the owner's expense if in the opinion of the Commission; there is a hazard to its equipment, personnel, or the public, arising out of the permit holder's incomplete or unsatisfactory work covered by a permit.
- c.) The Commission may allow construction activities during seasonal limitations if favorable weather and road conditions exist. The permit holder must get authorization from the Commission and is subject to any Supplemental Conditions deemed necessary by the Commission.
- d.) **SAFETY IS THE NUMBER ONE PRIORITY**
THE PERMIT HOLDER SHALL SHUT DOWN OPERATIONS AND REMOVE ALL EQUIPMENT FROM THE RIGHT OF WAY IF THE ROAD CONDITIONS OR VISIBILITY BECOME POOR, CREATING A HAZARD TO THE PUBLIC AND WORKERS.

H. Protection of existing utilities

- 1. Miss Dig
The permit holder must comply with the requirements of Act 53 of Public Acts of 1974, as amended. CALL MISS DIG AT (800) 482-7171 AT LEAST THREE (3) FULL WORKING DAYS, (EXCLUDING SATURDAYS, SUNDAYS AND HOLIDAYS) BUT NOMORE THAN TWENTY ONE (21) CALENDAR DAYS, BEFORE YOU START WORK. Permit holder assumes all responsibility for damage to or interruption of underground utilities.
- 2. Nonparticipating utilities with regard to Miss Dig
Not all utilities participate in the Miss Dig program. Calling Miss Dig does not relieve the permit holder of any responsibility for damage to nonparticipating utilities such as sewer or water lines. The permit holder is responsible for investigating the existence of, and contacting, nonparticipating utilities.
- 3. Drainage Structures
The permit holder is responsible for identification and protection of drainage structures such as culverts, in the work area.

I. Indemnity and Insurance

- 1. Indemnification
The permit holder shall hold harmless and indemnify the Commission, its officers, and employees for all claims, suits, and judgments to which the Commission, its officers or employees may be subject and for all costs and attorney fees which may be incurred on account of injury to persons or damage to property of the Commission, whether due to negligence of the permit holder arising out of the work under the permit, or in connection with work not authorized under this permit, or resulting from failure to comply with the terms of the permit, or arising out of the continued existence work product, which is subject to the permit.

2. Insurance requirements

Any contractor or individual performing permitted work in the right of way shall provide a certificate of insurance with the following coverages and minimum limits. The certificate must be on file with the Road Commission, prior to issuance of a permit. The certificate must contain the additional wording listed below* and will cover a period not less than the permit, and shall provide that it cannot be canceled without ten (10) days advance written notice by certified mail to the Commission. If the insurance is canceled without providing a new policy that meets these requirements the permit becomes void and shall be considered revoked on the same day and time that insurance coverage ends, with or without notice to permit holder.

DRIVEWAY AND MISCELLANEOUS PERMITS:

Automotive liability

Bodily Injury – per person.....	\$500,000.00
Bodily Injury – per accident.....	\$1,000,000.00
Property Damage.....	\$1,000,000.00
Combined Single Limit.....	\$1,000,000.00

General Liability

Each Occurrence.....	\$1,000,000.00
General Aggregate.....	\$1,000,000.00

****The following wording must be added to the certificate of insurance:***

“Additional insured per attached Endorsement #4”

-See page 1-25 for example of Endorsement #4

J. Conditions and Limitations in Permits

1. The Commission reserved the right of inspection by its authorized representatives of a driveway constructed within a road right of way. The permittee shall reimburse the Commission for the services of an on-the-job inspection, deemed necessary by the Commission.
2. **Permit Holder shall notify the Commission of the Start and Completion dates of work activities.**
3. A copy of the permit shall be available at the site during construction.
4. The permit holder shall take, provide, and maintain necessary precautions, to prevent injury or damages to persons and property from operations covered by the permit, and shall maintain traffic in accordance with SECTION 2 MAINTAINING TRAFFIC.
5. The permit holder shall surrender the permit and all rights thereunder when notified to do so by the Commission, because of its need for the area covered by the permit, or because of default of any provisions of the permit.
6. **Altered natural drainage shall not be permitted to flow onto the right of way, unless special provisions are approved by the Commission.**
7. The permit holder shall remove all surplus materials to an area outside of the right of way daily unless the permit provides otherwise. Excavated material shall be stockpiled so it does not adversely affect the safety of traffic.
8. The property owner, owner’s agent, or permit holder, shall construct and maintain the driveway(s) set forth in the permit, in a condition to prevent safety hazards, and damage to the right of way, from erosion, and vehicles entering and exiting the driveway. **If the use of the driveway causes damage to the road, pavement, shoulder or gravel surface; or if sand, mud, topsoil, gravel, debris, ect., is entering the traveled portion of the**

road, due to vehicle tracking and/or soil erosion; use of the driveway shall be immediately suspended until corrective action is taken. This condition is limited to the permit period and shall be the continued responsibility and liability of the property owner.

9. The applicant, the applicant's representative, or the property owner, shall perform all work and pay all costs in connection with permitted activities.
10. All utility service connections made in conjunction with the construction of a new driveway will be allowed under the driveway permit, provided that the traveled portion of the road, including the shoulder, are not disturbed. Utility connections that require the disturbance of the traveled portion of the road require a separate permit.
11. **A proposed driveway location shall not be used for an access point prior to placement of the required gravel base or surface.** The driveway shall be properly constructed and maintained to protect the public road from damage at all times.
12. **Driveways authorized by the permit shall be the only location where vehicles may enter or exit the public road, including during construction.**

K. Fees, Costs, and Sureties

1. Application Fee
See Fee Schedule and Driveway Permit Application Instructions. A permit will be considered void if a check used for payment of the permit fee is returned due to insufficient funds. The permit will not be reissued until the fee is collected along with any service fees charged by the bank.
2. Costs
Normally the permit holder will not be charged any costs other than the permit fee. The collection of costs in addition to the permit fee will be at the discretion of the Commission.
 - a.) The Commission is authorized by law to collect from the permit holder, his agent, or the property owner, all costs incurred by the Commission related to, or arising out of, the permitted activity, including, but not limited to, the following:
 - Costs for extended reviews of complicated or incomplete applications.
 - Costs for enforcement action taken.
 - Costs for on-site inspections deemed necessary by the Commission. (Initial and Final Inspections are covered by the permit fee.)
 - Costs for repairing damage to a public road that occurred as a direct result of the construction, use, or lack of maintenance, of a driveway.
 - b.) The permittee shall immediately reimburse the Commission in full for all such costs incurred by the Commission upon receipt of billing and that upon failure to pay, the Commission may affect payment with the performance surety deposit. If a surety deposit was not required, or if the surety deposit is insufficient to cover expenses incurred by the Commission, the permittee shall pay such deficiency upon billing by the Commission. State law provides for the collection of funds due the Commission by adding the amount to the owner's property tax bill. If a surety deposit exceeds the expense incurred, upon completion of the work to the satisfaction of the Commission, any excess will be returned or released to the depositor.
 - c.) Costs for actions undertaken by Commission personnel and equipment shall be determined as follows: labor (charged at the current rate, plus fringe benefits), published equipment rates, any material at cost, all plus comprehensive liability and overhead.
 - d.) All other costs. Including, but not limited to, the following:
Services provided by others for the Commission.

- Legal Services
 - Professional engineering, testing, or inspection services.
 - Professional surveying services.
 - Construction or maintenance contractor services for repair or damages, or for completion of work called for in a permit.
- e.) All court costs and related legal fees associated with collection of funds due the Commission or enforcement of permit regulations.
3. Surety or Cash Deposit
- The permittee shall, upon request of the Commission, furnish a performance surety deposit in the form of cash, certified check, or irrevocable bank letter of credit. Requirements for an Irrevocable Bank Letter of Credit: letter of credit shall be issued for a period of 2 years and the letter of credit shall be issued by a bank within a 60 mile radius of the Emmet County Road Commission. The amount of the deposit will be as deemed necessary by the Commission to guarantee performance under the conditions of the permit, completion of work, and restoration of the right of way to the satisfaction of the Commission.
- a.) Commercial Driveways (per driveway)
- The following shall apply unless specified or approved otherwise by the Commission
- \$15,000.00 Cash, Certified Check, or irrevocable bank letter of credit (Irrevocable letter of credit must be on Emmet County Road Commission form)
 - If county road improvements are necessary, 100% of the cost of the necessary road repairs, including driveway improvements, as decided under Section 1.2 part D, Number 3 of the Permit Requirements, shall be provided to the Road Commission in the form of a cash deposit, Certified Check, or irrevocable bank letter of credit (Irrevocable letter of credit must be on Emmet County Road Commission form)
- b.) All driveways other than Commercial
- Surety or cash deposits are not required for driveways other than commercial driveways with the following exceptions:
- Unusual or challenging site conditions exist and in the opinion of the Commission, a surety or cash deposit is needed to ensure proper installation and completion.
 - Permittee fails to complete the permitted work during the permit period.
 - Enforcement action or cost collection was required on a previous permit issued to the applicant or contractor.
- The amount of the surety or cash deposit, if required, will be determined by the Commission.
- c.) Release of Surety or Cash Deposit
- Final Inspection and acceptance by the Commission are required for the release of a Surety or Cash Deposit. The applicant shall submit the *Request for Final Inspection* form, funds due the Road Commission will be deducted from any cash deposit before release. An irrevocable letter of credit will not be released if there are outstanding funds due the Commission.

L. Enforcement

1. Michigan law authorizes the Road Commission to initiate both criminal and civil action. If a person fails to comply with any provision of a permit, fails to obtain the appropriate permit, or undertakes activities in the right of way that are not permitted or are prohibited, the Commission will initiate whatever enforcement action it deems

necessary to correct for the noncompliance. Costs incurred by the Commission for correcting for noncompliance, defective workmanship or materials shall be borne by the permit holder, person undertaking the activity, or the property owner.

2. Enforcement guidelines. The following permit violations and corresponding corrective actions are outlined for the purposed of example and shall not be construed to limit the Commission to the actions listed here.
 - a.) Failure to obtain a permit
 - Obtain a permit and pay the permit fee, including fine (if assessed).
 - The Commission may halt the construction and/or use of the driveway until a permit is obtained and the fee and fine paid.
 - The Commission may deny the permit and remove the driveway.
 - Pay any fines and fees as established by the Emmet County Road Commission, see attached Schedule of Fees.
 - b.) Failure to comply with permit requirements
 - The Commission may halt the construction and/or the use of the driveway until adequate corrections have been made.
 - The Commission may undertake repairs, maintenance, or complete the construction of a driveway. The Commission may elect to do the work with its forces, or by contracting the work.
 - The Commission may remove the driveway and revoke or deny a permit.
 - Emergency work deemed necessary by the Commission for public safety or protection or repair of the right of way may be done without notice to the property owner or permit holder, and will be at the property owner's or permit holder's expense.
 - Future permits may be held at the discretion of the Commission if there are any outstanding violations or fees on past or current projects.
 - Pay any fines and fees as established by the Emmet County Road Commission, see attached Schedule of Fees.
3. Road Commission right to revoke a permit.

The Road Commission has the right to revoke an issued permit if any requirements requested by the Road Commission are not complied with (pursuant to Section 247.326, Section 6, of the Michigan Compiled Laws.)

M. Commercial Driveway Construction

The Applicant shall hard surface the driveway within 45 days of the concrete curb gutter installation. If not completed within the 45 days, the Road Commission will take enforcement action.

1.3 Specifications and Design Standards

A. Driveway Locations

A driveway shall be located to provide the most favorable vision and grade condition possible in the interest of public safety. The Commission may deny or require a driveway location to be moved. All driveways shall be approved by the Commission, prior to use, based on the following criteria.

1. Sight Distance

Sight distance will be evaluated using current guidelines based on prevailing speeds at the site according to the following tables, using Height of Eye at 3.5 feet and Height of Object at 2.0 feet.

- a.) All driveways other than Commercial use Table 1-1: **Stopping Sight Distance**. The available sight distance should be of sufficient length to enable a vehicle at or near the design speed to stop before reaching a stationary object in its path. Stopping sight distance is the sum of brake reaction distance and braking distance.

TABLE 1-1: STOPPING SIGHT DISTANCE

Assumed Speed for Condition (Mph)	Stopping Sight Distance (feet)
20	115
25	155
30	200
35	250
40	305
45	360
50	425
55	495
60	570

- b.) Commercial Driveways use Table 1-2: **Intersection Sight Distance**. The sight distance provided at intersections allows the drivers of stopped vehicles a sufficient view of the intersecting roadway to decide when to enter the intersecting roadway or to cross it. The time required is the sum of perceptions reaction time plus the time to accelerate and cross or enter the roadway traffic stream.

TABLE 1-2: INTERSECTION SIGHT DISTANCE

Assumed Speed for Condition (Mph)	MDOT Criteria 8 sec. x 1.47 x Speed (feet)
25	295
30	350
35	410
40	470
45	530
50	590
55	650
60	710

2. Encroachment on other properties

- a.) A driveway, including the radii and culvert, but not including the right turn lanes and tapers, shall be located entirely within the permittee's property lines extended to the centerline of the road. A drive radii or culvert may extend outside of that area, only if the adjacent property owner will certify in writing that such extension is permitted.
 - b.) It is the responsibility of the applicant or property owner to ensure that the driveway location satisfies the requirement of (a) above and any applicable zoning requirements. The Road Commission accepts no responsibility for verification of property lines or zoning compliance.
3. Proximity to a road intersection
If a driveway is located adjacent to a road intersection, the following shall apply:
- a.) If the intersecting road is curbed, the point of curvature of the driveway radius shall be at least 20 feet from the point of curvature of the intersecting road radius.
 - b.) If the intersecting road is uncurbed, the point of curvature of the driveway radius shall be at least 50 feet from the edge of pavement of the intersecting road radius.
 - c.) When an existing road or driveway is reconstructed, or the requirements in paragraphs (a) and (b) cannot be complied with, the driveway radius shall not encroach upon the intersection radius, unless such encroachment is physically unavoidable.
 - d.) A driveway shall not be constructed along the acceleration or deceleration lanes or tapers unless no other reasonable access point is available.
4. Number of driveways and separation
- a.) Residential Driveways
The number of residential driveways shall be determined as follows:
 - One residential driveway will be permitted for each platted lot or for unplatted residential property with less than 100 feet of frontage.
 - One additional residential driveway may be permitted for residential property for each 70 feet of frontage in excess of the first 100 feet of frontage.
 - Two residential driveways may be permitted on the same property, in lieu of other requirements, to service a circle driveway if the frontage is 80 feet or more.
 - Residential driveways on the same property shall be at least 45 feet apart, center to center.
 - b.) Field Entrances
One field entrance may be permitted for each 1000 feet of frontage of cultivated land, or undeveloped land. Additional driveways may be permitted when a single driveway will not provide adequate access due to topographical conditions.
 - c.) Commercial and Multifamily Residential Driveways and Access or Haul Roads
Number and separation of these driveways shall be evaluated on a case by case basis.

B. Clear Vision and Buffer Areas

Adjacent to and on both sides of a driveway, a buffer area between the right of way line and the edge of pavement shall be used, as determined by the Commission, to provide a physical barrier between road traffic and activity on private property. A buffer area is needed to provide a unobscured vision area and to prevent potentially hazardous movement of vehicles, especially at undesirable angles of approach, from and to the road. The buffer area shall consist of a lawn area, a low-shrub area, a ditch or equivalent. Where encroachment of vehicle parking on the

buffer takes place, or may take place, the Commission may require the buffer area be established by guardrail, guard posts, curb or equivalent.

C. Drainage

1. A driveway shall be constructed so that it does not adversely affect the drainage of the road or the right of way. The drainage and stability of the road subgrade shall not be altered by driveway construction or roadside development.
2. If post development (altered natural) drainage into the right of way is increased, special provision must be approved by the Commission, such as:
 - a.) Retention pond(s) with metered release.
 - b.) Increasing the capacity of or creating a roadside ditch.
 - c.) Installation of permanent soil erosion control measures.
 - Sodding and seeding
 - Rip rap, cobble ditches, asphalt spillways and stone check dams.
 - Paving of the driveway surface (mandatory for commercial driveways.)
3. Under drains for driveway, parking areas, yards, building foundations, ect. will not be allowed to discharge directly into the right of way.
4. **Drainage from the driveway or site shall NOT enter the traveled portion of the road, including the shoulder, except in unusual circumstances and only with approval from the Commission.**

D. Culverts

1. Necessity
A Commission inspector will determine if a culvert is required.
2. Materials
Corrugated metal or corrugated plastic culverts that meet MDOT specifications. Plastic culverts shall have a smooth, non-corrugated inner wall.
3. Culvert Size
Pipe diameter and length shall be as specified below, or as specified by the Commission.
 - a.) Culvert Diameter
Culvert pipe shall be of a size adequate to carry the anticipated natural flow of the ditch. The culvert shall be no smaller than the nearest upstream culvert, nor less than 12 inches in diameter.
 - b.) Culvert Length
The minimum length of culvert may be determined and the sum of the distance between driveway edges, measured along the ditch line, plus the distances needed to accommodate an embankment slope not to exceed 1 foot vertical for 6 feet horizontal on both sides of the driveway, but no less than 30 feet (see Figure 1-5.)
4. Culvert End Sections
Metal endsections are required for culverts with a diameter of 18 inches and larger, and are recommended for culverts less than 18 inches.
5. Cover, Bedding and Fill
 - a.) Cover
A minimum of 1 foot (or manufacturer recommended amount) of cover shall be placed over the culvert. The required driveway profile must be maintained. Do not ramp the driveway over the culvert to accomplish the 1 foot cover. If the ditch is not deep enough to allow for the required cover and maintain the profile, the ditch shall be cleaned out as described below.
 - b.) Bedding and Fill
Material used for culvert bedding and fill shall be free draining granular material (sand or gravel) meeting MDOT Class II specification.
6. Ditch Clean-out

The ditch shall be excavated as needed in each direction to provide a flow line through the culvert and allow for cover over the culvert and proper driveway profile. Ditch foreslopes shall be 1 on 3 or flatter, and ditch backslopes shall be 1 on 2 or flatter (see Driveway Profile). The length of ditch clean-out that the permit holder is responsible for is limited to 50 feet in either direction of the driveway for all driveways other than Commercial.

E. Material and Density Requirements

Material and density requirements shall be in accordance with the plans, specifications, additional permit requirements, MDOT's Density Control Handbook and as specified herein.

1. Gravel Surfaces and Shoulders
 - a.) Material
MDOT 23 A Gravel
 - b.) Density
Compact to 98 percent density.
2. Aggregate Base under Hot Mix Asphalt Pavement
 - a.) Material
MDOT 22 A Gravel
 - b.) Density
Compact to 98 percent density.

F. Surfacing

1. All driveways shall be constructed, surfaced and maintained to provide adequate stability capable of supporting the vehicles using the driveway. The driveway shall be constructed and maintained flush with the existing road surface to prevent damage to the public road. The driveway shall be constructed and maintained in a condition to prevent sand, mud, gravel, debris, ect from entering the public road due to soil erosion, or from vehicles tracking the material out onto the road.

The following minimum driveway surfacing and curbing requirements apply:

- a.) Residential driveways may be paved or surfaced with stabilized gravel.
 - Minimum gravel thickness is 6 inches.
 - Minimum pavement thickness (optional). For asphalt surfaces, 2 inches of asphalt on 6 inches of gravel. For concrete surfaces, 4 inches on a free draining base.
- b.) Field Entrance or Utility Structure driveways may be surfaced with 6 inches of stabilized gravel or with sod over a stabilized gravel base.
- c.) Access or Haul Road driveways.
 - Minimum gravel thickness is 8 inches.
 - Minimum pavement thickness (may be required in special cases). Two (2) inches of asphalt on 6 inches of gravel.

This category of driveway covers a large range of use, and therefore each permit will be evaluated on a case by case basis to determine what design feature and surfacing requirements should apply, considering such things as frequency, duration and type of use. The standards provided for this category will apply, unless otherwise stated in the issued permit.

- d.) Multifamily Residential Driveways
 - Minimum gravel thickness is 6 inches under pavement.
 - Minimum pavement thickness (required). For asphalt surfaces, 2 inches of asphalt on 6 inches of gravel. For concrete surfaces, 4 inches on a free draining base
- e.) Commercial Driveways
 - Minimum gravel thickness is 8 inches under pavement.

- Minimum pavement thickness (required). For asphalt surfaces, 3 inches of asphalt on 8 inches of gravel. For concrete surfaces, 6 inches on a free draining base
- Concrete Curb and Gutter, Det B2 (MDOT Specification) is required.

G. Driveway Profile

The driveway profile shall be determined using the following criteria:

1. All driveways other than Commercial (see Figure 1-3):
 - a.) Paved roads
The grade of the driveway between the road edge of pavement and the outside edge of the shoulder shall conform to the slope of the shoulder.
 - b.) Unpaved roads
The grade of the driveway shall slope downward from the edge of the graveled surface at a minimum of ½ inch per foot of fall (2 percent) for a minimum distance of 6 feet.
 - c.) Maximum grade
The grade for driveways beyond the portion outlined above shall not exceed 10 percent.
2. Commercial Driveways
 - a.) The entire width of the driveway including turn lanes and tapers shall slope away from the edge of the 11 foot wide driving land or white line at 2 percent all the way to the face of curb (see dimension G in figure 1-2.)
 - b.) The driveway profile may change in a positive or negative direction beyond the curb line described above, but shall not exceed 10 percent.

H. Restoration

1. Turf Establishment
All disturbed areas shall be restored with topsoil, seed, fertilizer and mulch in a timely manner for the purpose of erosion control. All restoration shall be completed no later than five (5) days after completion of earthwork activities. The Commission may require other temporary and permanent soil erosion control measures deemed necessary for protection of the road right of way and adjacent properties.
2. Shoulders
The public road shoulder shall be maintained flush with the driveway surface and road on both sides of the driveway. The grade and slope of the road shoulder shall continue across the driveway approach as not to create a bump or a dip that could be a hazard to motorists or maintenance vehicles traveling the shoulder. If the shoulders are not maintained flush daily during construction, lighted must be placed along the low shoulder area with a maximum spacing of 25 feet and a minimum of two barrels, one at each end.
3. Tree and Stump Removal
If trees are removed from the right of way, the stumps shall be removed as follows:
 - a.) Within the 10 foot clear zone, defined as 10 feet from the edge of the outside driving lane (white line if present.) Driving lanes are typically 11 to 12 feet in width. The clear zone begins at the outside edge of the outermost driving lane, not the outside of the road shoulder. All stumps in the described area shall be removed or ground below the surface elevation.
 - b.) Outside the 10 foot clear zone, stumps shall be flush cut, removed or ground.

I. Plan Requirements

1. All driveways other than Commercial
 - a.) Plans are not required unless specifically requested by the Commission.

- b.) The Commission reserves the right to require detailed and/or engineered site and drainage plans where, in the opinion of the Commission, unusual or challenging site conditions exist and detailed plans are needed in order to make decisions as to the application.
2. Commercial Driveways
A detailed and engineered site plan, drainage plan and driveway design plan, is required.
- a.) Site Plan Requirements
 - Plan view of the property and right of way
 - Facility to be constructed, driveways, roads, parking lots, ect.
 - Distance to nearest intersecting road or street, nearest driveway or adjacent properties, roads, streets or driveways opposite the site, property lines, curb, sidewalks, and signs.
 - b.) Drainage Plan Requirements
 - Existing and proposed site elevations and contours, including the right of way.
 - Direction of water flow (drainage arrows.)
 - Proposed drainage outlets and all invert elevations.
 - Outlet pipe size and material.
 - Computations for detention or retention pond volumes (when required by the Road Commission or other agency)
 - c.) Driveway Design Plan Requirements
 - Proposed driveway layout.
 - Curb and gutter elevations (face of curb.)
 - Existing road with elevations at centerline, and the edge of the driving lane (match line of driveway and road.) Road elevations shall be provided corresponding to the following locations at a minimum:
 - End of tapers
 - End of curbs
 - Curb radius points
 - Center line of driveway
 - Size and length of driveway culvert, culvert material, culvert diameter, end treatment and direction of flow.
 - Proposed pavement section.
 - Proposed sign locations and legend.
3. County Road Improvement Plan Requirements (if needed)
- a.) Current layout of the county road impacted by the development, including elevations of centerline, the edge of driving lane, ditch line and right of way limits.
 - b.) Proposed improvements to county road(s), including driveway improvements, turning lanes, passing lanes, lane lining, intersection improvements, road drainage (including culvert sizes and ditching), proposed signing (per MMUTCD requirements), detour plans, existing utility locations, proposed pavement section and sub-surface borings.

J. Design Features

1. Uncurbed Roads

The design features in this rule, and illustrated in Figures 1-1 thru 1-4, shall be used by the applicant in dimensioning a proposed driveway or driveway system. The dimensions to be used for various driveway design features are given as a standard with a working range of dimensions. These standard dimensions shall be used unless conditions

warrant a deviation. The Commission may specify dimension so a particular driveway system will accommodate vehicle movements normally expected without creating undue congestion or hazard on the road, or to provide reasonable access.

The letters in the following design features refer to features in Figure 1-1 and Figure 1-2:

- A Intersecting Angle:** the clockwise angle from the road centerline to a driveway reference line, which is the driveway centerline, or the edge of the driveway.
- B Driveway Width:** The distance between the driveway edges of pavement or edges of the gravel surface measured at the point where the edges of the driveway become parallel.
- C Entering Radius:** The radius of the driveway edge curve on the right side of a vehicle entering the driveway.
- D Exiting Radius:** The radius of the driveway edge curve on the right side of a vehicle leaving the driveway.
- E Curb Ending (tangent):** The length of the height transition from pavement level to full curb height, tangent to the radius, and parallel to the road centerline.
- F Right turn lane length:** The length of an auxiliary land constructed preceding the driveway to accommodate right turn traffic entering the driveway.
- G Right turn lane width (curb set back):** The width from the edge of the road driving lane to face of curb. Paving shall extend to the back of curb.
- H Entering taper length:** The length of pavement widening preceding the driveway or right turn lane. If a right turn lane is not required by the Commission, the taper shall extend to the back of curb.
- I Driving lane width:** The standard width of lane from the centerline to the white line. Lane width is 11 feet from the center of the road, regardless of the location or absence of the white line.
- J Exiting taper length:** The length of pavement narrowing from back of curb to the edge of the driving lane.

2. Curbed roads (MDOT Standards)

The amount of curbed road within the jurisdiction of the Commission is so small that it does not warrant adoption or publishing of extensive design details and standards specific to curbed roadways. Applications for driveway permits on curbed sections of road shall include a plan or drawing of the proposed driveway according to current Michigan Department of Transportation standards for the type of driveway proposed, for the Commission's review and approval.

K. Sign Requirements

Commercial driveways that serve 5 or more homes and/or lots shall have a "Stop" sign installed that meets the current requirements of the *Michigan Manual of Uniform Traffic Control Devices*. The "Stop" sign shall be placed outside of the public road right of way (see figure 1-6.) The minimum size of the "Stop" sign shall be 30 inches. The irrevocable letter of credit or cash deposit will be withheld until the "Stop" sign installation is completed.

PERMIT / LAND DIVISION FEE SCHEDULE

Effective July 1, 2019

DRIVEWAYS	FEE
Residential Driveway, Rural (shoulder/ditch)	\$ 50.00
Upgrade Residential Driveway Approach	\$ 40.00
Commercial Driveway Approach	\$ 200.00
Private Road Approach (5 access points or more)	\$ 200.00
Farm Field Driveway Approach	\$ 50.00
Temporary Construction Driveway Approach	\$ 150.00
UTILITIES	
Overhead Utility Installation	\$ 200.00
Underground Utility Installation	\$ 200.00
Utility Service Connection	\$ 125.00
Sanitary, Water Main, or Storm Connection	\$ 200.00
Open Cut Road Crossings (+Restoration Cash Bond)	\$ 500.00
Bore Road Crossings (+Restoration Cash Bond)	\$ 150.00
OTHER	
Grading / Drainage (ditch enclosure / sealed plans)	\$ 100.00
Soil Borings	\$ 75.00
Landscaping including vegetation removal	\$ 50.00
LAND DIVISION	\$ 150*, plus \$50 for each additional split. *Fee includes one residential permit of \$50.

DRIVEWAY FEATURES

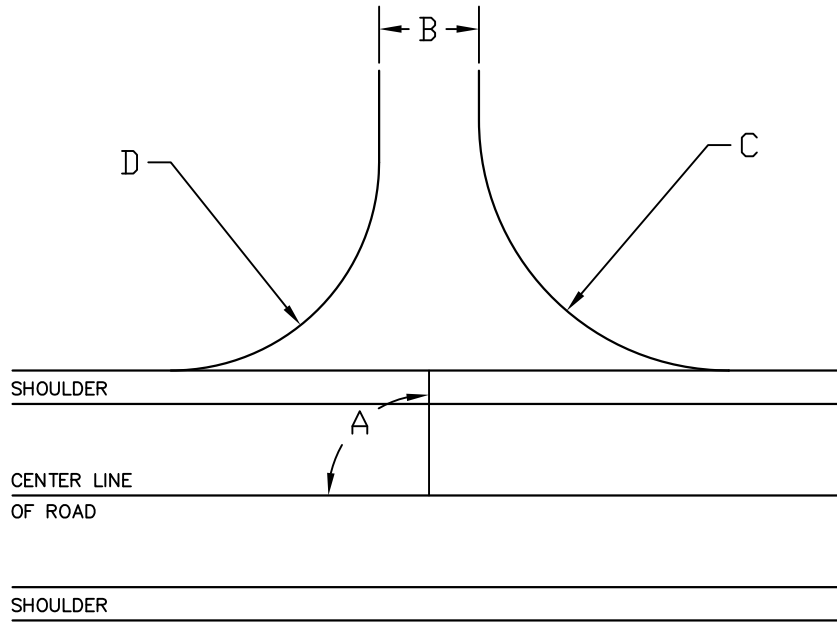

RESIDENTIAL DRIVEWAYS

DESIGN FEATURES		STANDARD	RANGE
INTERSECTING ANGLE	A	90°	70° to 110°
DRIVEWAY WIDTH	B	12 ft.	8 to 24 ft.
ENTERING RADIUS	C	15 ft.	5 to 20 ft.
EXITING RADIUS	D	10 ft.	5 to 20 ft.

FIELD, UTILITY ACCESS OR HAUL AND MULTI-FAMILY RESIDENTIAL DRIVEWAYS

DESIGN FEATURES		STANDARD	RANGE
INTERSECTING ANGLE	A	90°	70° to 110°
DRIVEWAY WIDTH	B	20 ft.	15 to 40 ft.
ENTERING RADIUS	C	20 ft.	5 to 40 ft.
EXITING RADIUS	D	20 ft.	5 to 40 ft.

FIGURE 1-1 : DRIVEWAYS OTHER THAN COMMERCIAL

DRIVEWAY FEATURES

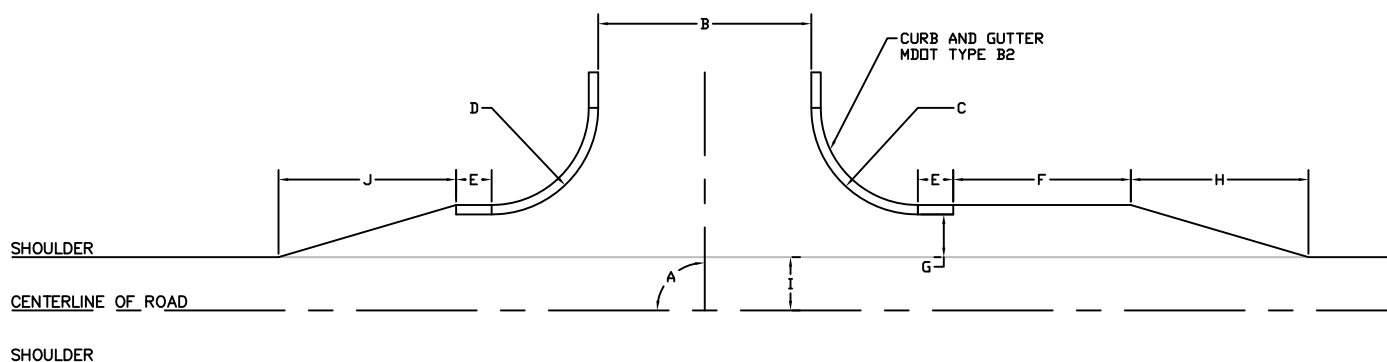

COMMERCIAL DRIVEWAYS

DESIGN FEATURES		STANDARD	RANGE
INTERSECTING ANGLE	A	90°	60° to 120°
DRIVEWAY WIDTH	B	30 ft.	15 to 50 ft.
ENTERING RADIUS	C	30 ft.	5 to 50 ft.
EXITING RADIUS	D	30 ft.	5 to 50 ft.
CURB ENDING	E	10 ft.	no range
RIGHT-TURN LANE LENGTH	F	as determined by the road commission	
RIGHT-TURN LANE WIDTH	G	12 ft.	10 to 15 ft.
ENTERING TAPER	H	150 ft.	50 to 150 ft.
LANE WIDTH	I	11 ft.	no range
EXITING TAPER	J	50 ft.	50 to 150 ft.

CONCRETE CURB AND GUTTER MDOT TYPE B2

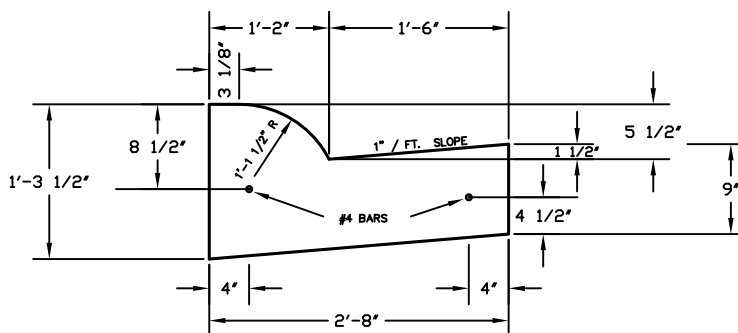

FIGURE 1-2 : COMMERCIAL DRIVEWAYS

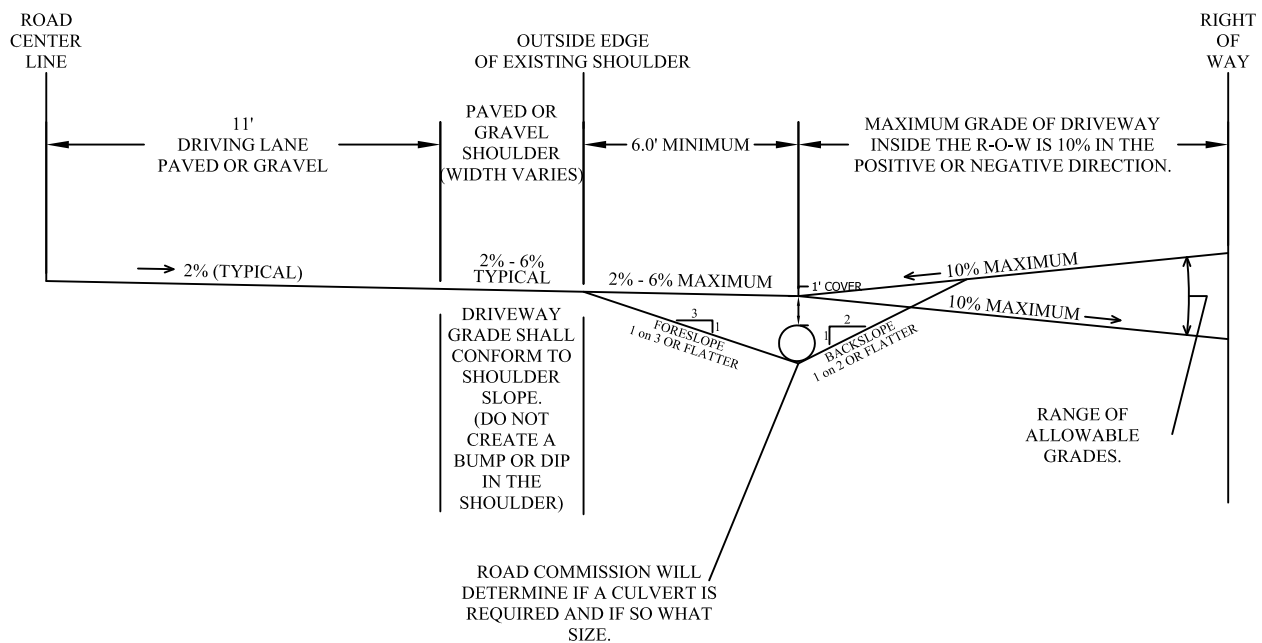

FIGURE 1-3 : DRIVEWAY PROFILE OTHER THAN COMMERCIAL

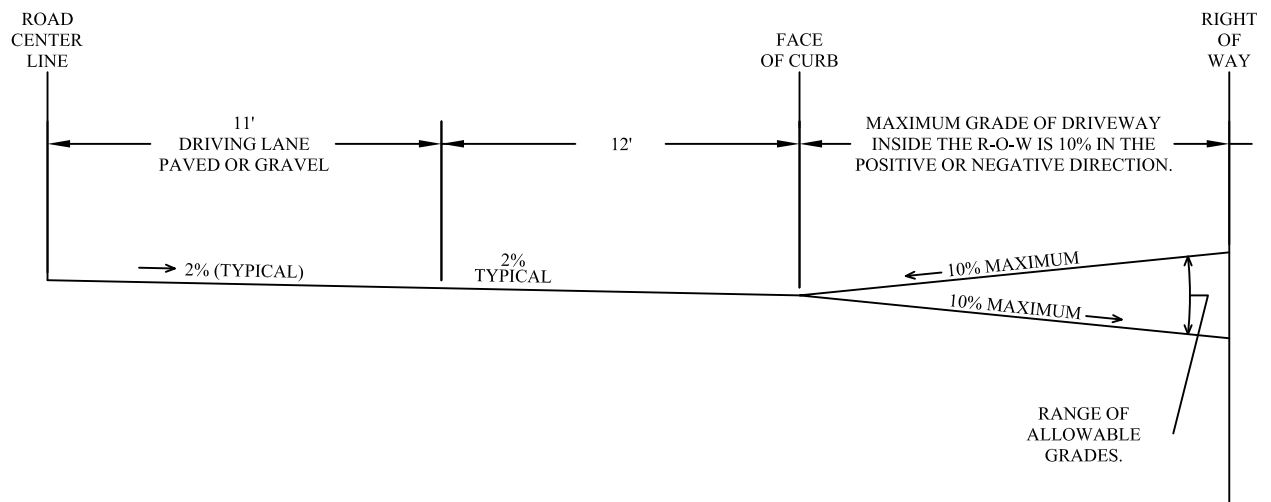

FIGURE 1-4 : DRIVEWAY PROFILE COMMERCIAL

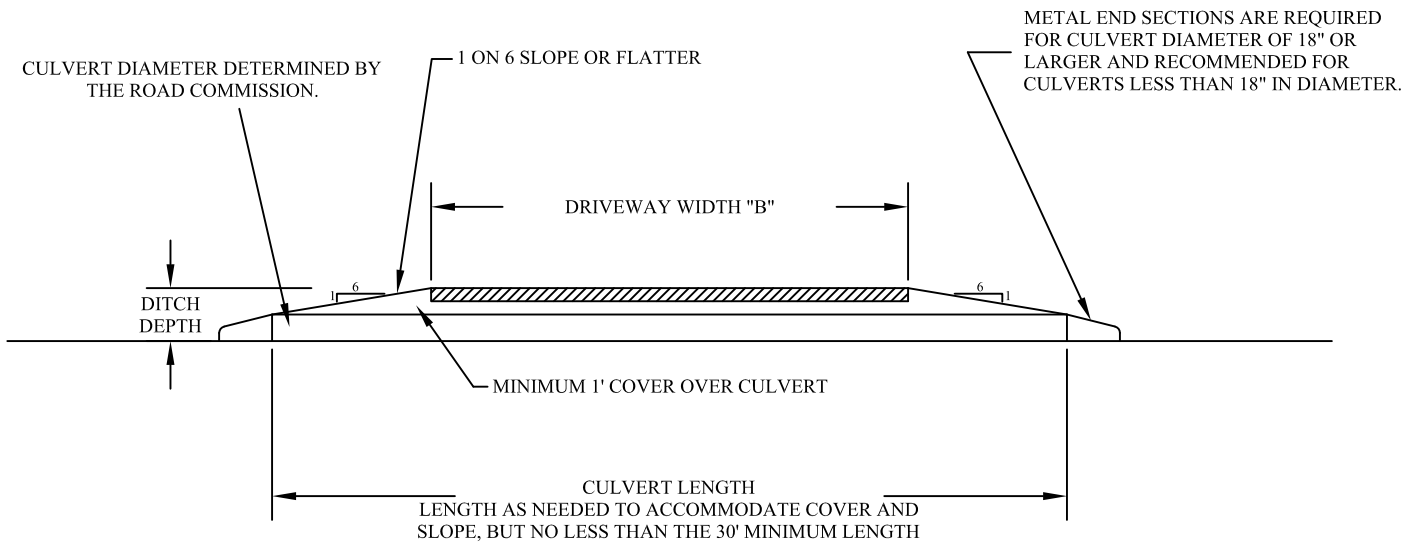

FIGURE 1-5 : DRIVEWAY CROSS SECTION

GUIDELINES FOR PLACING PRIVATE ROAD SIGNS

RIGHT OF WAY

CENTERLINE OF COUNTY ROAD

RIGHT OF WAY

- INSTALL STOP SIGN BETWEEN 5' - 7' ABOVE THE ROAD SURFACE
- POST DEPTH SHOULD BE BETWEEN 30" - 48"

** 34' MINIMUM FROM CENTERLINE OF COUNTY ROAD, 50' MAXIMUM FROM EDGE OF PAVEMENT ON COUNTY ROAD.

34.0' **

6' - 12'

STOP SIGN &
ROAD NAME SIGN

FIGURE 1-6 : SIGN LOCATION

ENDORSEMENT #4
BLANKET ADDITIONAL INSUREDS
GENERAL LIABILITY

Owners, Manager or Lessors of Premises

Any person or organization that is a premises owner, manager or lessor is an insured, but only with respect to liability arising out of the ownership, maintenance or use of that part of any premises leased or loaned to you.

This coverage provided to such premises owner, manager or lessor does not apply to:

1. Any bodily injury or property damage caused by an occurrence that takes place, or personal injury caused by an offense that is committed, after you cease to be a tenant in or to borrow that premises; or
2. Structural alterations, new construction or demolition operations performed by or on behalf of such premises owner, manager or lessor.

Lessors of Leased Equipment

Any person or organization that is an equipment lessor is an insured, but only with respect to liability for bodily injury, property damage or personal injury caused, in whole or in part, by your acts or omission in the maintenance, operation or use by you of equipment leased to you by such equipment lessor.

The insurance provided to such equipment lessor does not apply to any bodily injury or property damage caused by an occurrence that takes place, or personal injury caused by an offense that is committed, after the equipment lease expires.

Persons or Organizations for Your Ongoing Operations as Required by Written Contract or Agreement

Any person or organization that is not otherwise an insured under this Coverage Part and that you have agreed in a written contract or agreement to include as an additional insured on this Coverage Part is an insured but only with respect to liability for bodily injury, property damage or personal injury that:

1. Is bodily injury or property damage caused by an occurrence that takes place, or is personal injury caused by an offense that is committed, after you have signed and executed that contract or agreement; and
2. Is caused, in whole or in part, by your acts or omissions in the performance or your ongoing operations to which that contract or agreement applies or the acts or omissions of any person or organization performing such operations on your behalf.

The limits of insurance provided to such insured will be the limits which you agree to provide in the written contract or agreement, or the limits shown in Declarations, whichever are less.